

Site plan

LEGEND

- Aquatics - pool
- Aquatics - change
- Aquatics - lifeguard, sauna/steam, party room, storage, staff
- Aquatics - back of house & mechanical
- Welcome Centre, lobby, circulation
- Community Centre - gymnasium
- Community Centre - multi-purpose
- Community Centre - childcare
- Multi-use pathway
- Plaza & walkway
- Greenscaping & bioswales
- △ Entry
- Sewer easement
- Property line
- Existing buildings

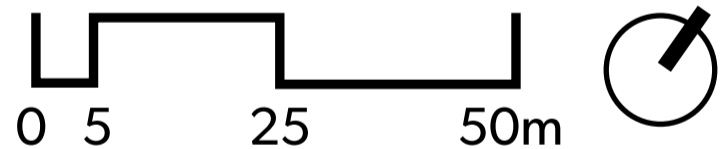

Get involved...

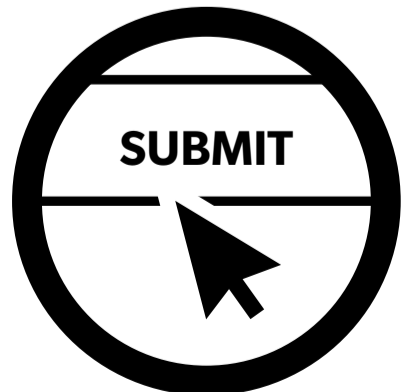

Complete the online survey
youractivenewwest.ca/survey

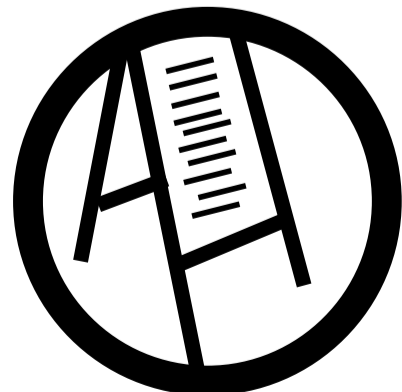

Attend a public meeting

EMAIL
youractivenw@newwestcity.ca

GIVE US A CALL
 Parks and Recreation Administration
 604-527-4567

SOCIAL MEDIA
 Follow us to receive updates and share your thoughts using the hashtag **#YourActiveNW**

f facebook.com/nwparksrec
t [@newwestrec](https://twitter.com/newwestrec)
[@new_westminster](https://twitter.com/new_westminster)

Proposed solution

AQUATICS

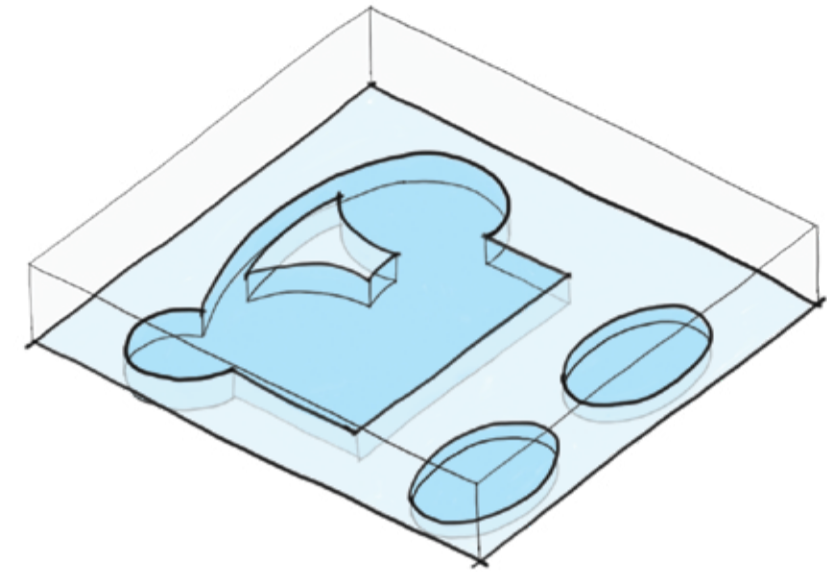

LEISURE

- Leisure swimming
- Lessons
- Warm-up / down
- Therapy
- Sauna & steam rooms
- Lazy river
- Hot pools
- Tot zone

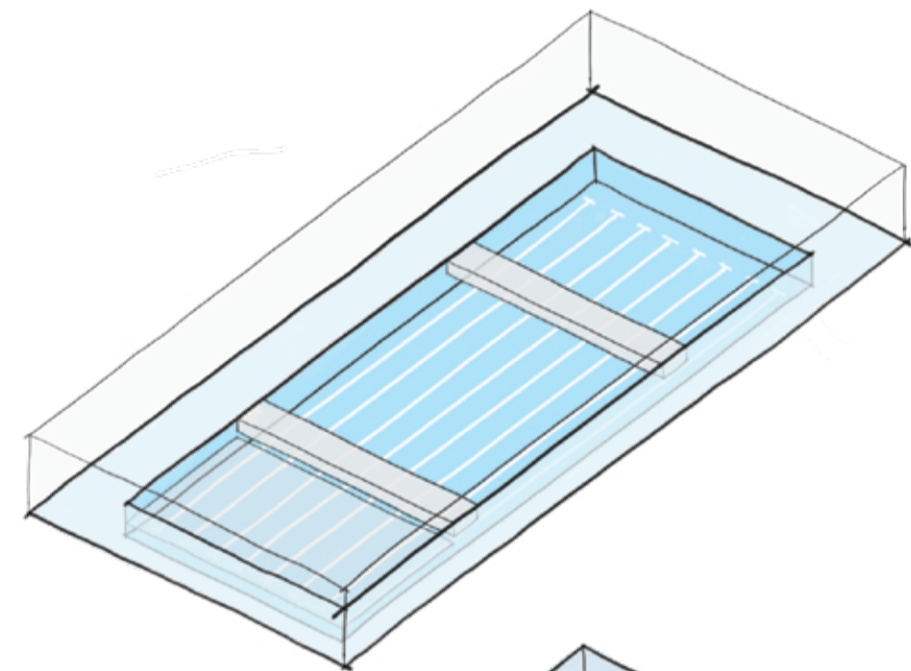

PROGRAM TANK 50M

- Length swimming
- Aquatic group fitness
- Swim lessons
- Leisure diving

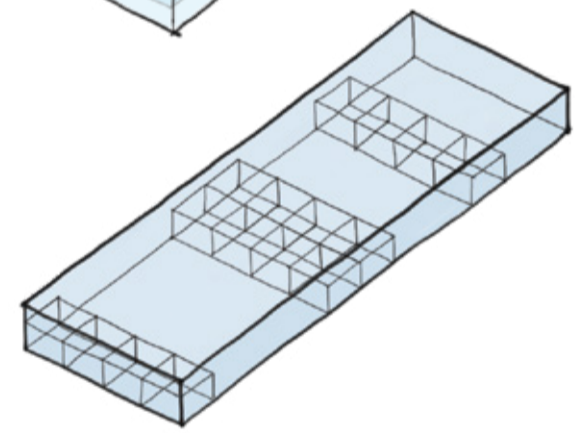

CHANGE ROOMS

- Universal access

FITNESS

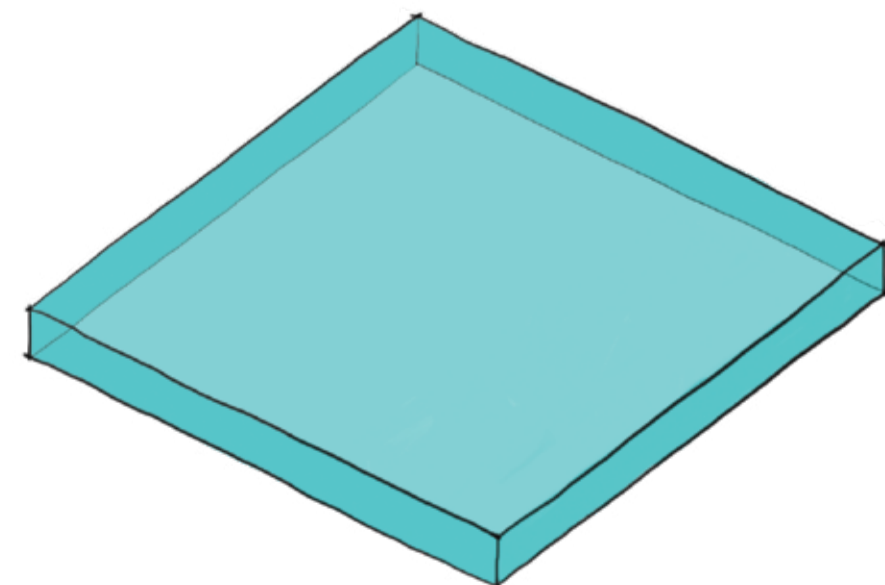

- Cardio
- Spin
- Free weights
- Stretching

COMMUNITY

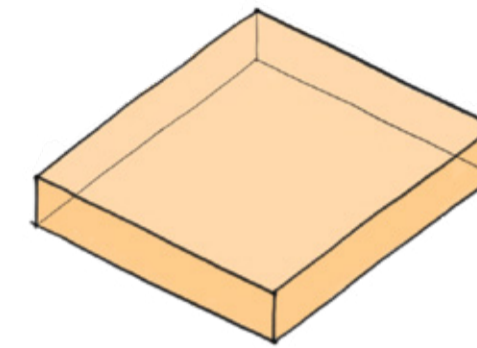

WELCOME CENTRE

- Informal social gathering
- Community events
- Cafe

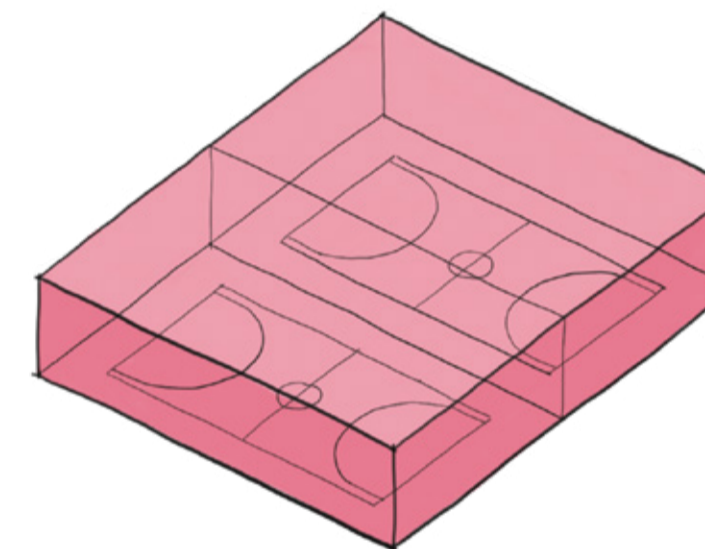

GYMNASIUM

- Basketball
- Volleyball
- Pickleball
- Badminton
- Floor hockey
- Other non-sport activities

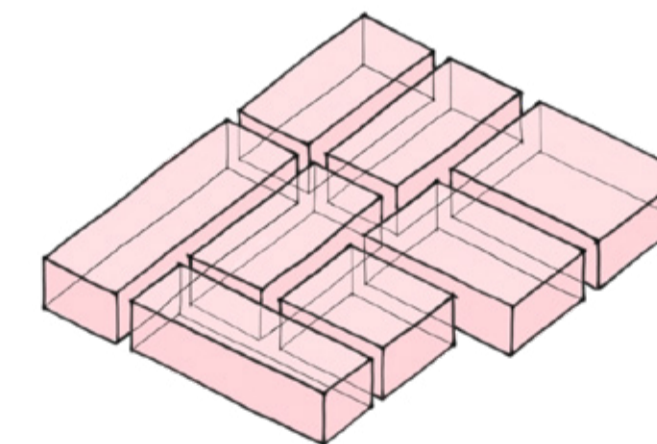

MULTI-PURPOSE

- Arts & crafts
- Childminding
- Group fitness classes
- Meetings
- Bookable spaces

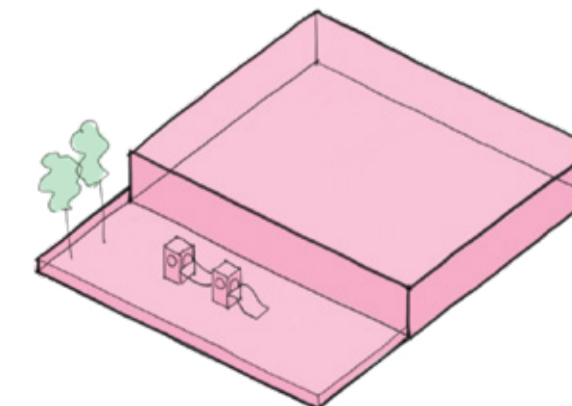

CHILDCARE

- Daycare
- Outdoor play space

Total estimated project cost: ~\$100 Million

Total area: 114,295sq ft

The new facility will be 65% larger than the existing 70,000 CGP/CCC.

What's next?

We want to know if we're on the right track for the new aquatics and community centre.

In the next phase of community and stakeholder engagement, we will:

- Check-in with the community about the proposed program components for the new facility.
- Evaluate trade-offs and ensure the community's values are reflected in the new facility and programming.

Get involved...



Complete the online survey
youractivenewwest.ca/survey



Attend a public meeting

www.youractivenw.ca

Learn more

To learn more about The Future New West Aquatics and Community Centre project, or to read the full feasibility study, please visit our project website: www.youractivenw.ca

EMAIL

youractivenw@newwestcity.ca

GIVE US A CALL

Parks and Recreation Administration
604-527-4567

SOCIAL MEDIA

Follow us to receive updates and share your thoughts using the hashtag **#YourActiveNW**

facebook.com/nwparksrec

[@newwestrec](https://twitter.com/newwestrec)

[@new_westminster](https://www.instagram.com/new_westminster)

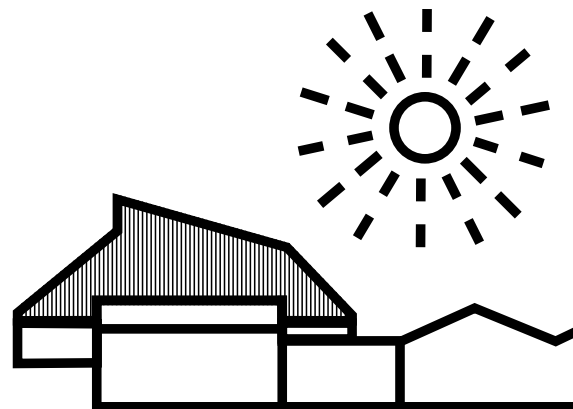

PROJECT FACT SHEET

THE FUTURE NEW WEST AQUATICS & COMMUNITY CENTRE

Building a recreation
destination for
Your Active New West

#YourActiveNW

NEW WESTMINSTER

Background

The Canada Games Pool and Centennial Community Centre are an important part of active, healthy living in New Westminster – yet both facilities are aging and in a state of decline.

In 2016, the City asked the community and stakeholders to weigh in about the future of these two legacy facilities. They asked: “What’s possible for the renewal of these recreation and community spaces?” This feedback, coupled with a 2017 feasibility study recommended the construction of a new aquatics and community centre that reflects the unique identity of New Westminster.

The new facility will be constructed in a single phase and cost in the order of \$100M. The existing Canada Games Pool and Centennial Community Centre will remain operational during construction.

What we heard

98%

of residents said aquatics and community centres are “important” to the identity and community of New Westminster.

59%

of residents said they’d be “more likely” to visit the aquatics centre if it were renewed.

Residents and stakeholders expressed a desire for a recreational and community amenities that will advance New Westminster’s rich tradition of sports excellence; with welcoming and inclusive gathering spaces for all.

Community priorities

Dear City Council,
The renewed aquatic and community facilities should be...

built upon the success and high caliber of the existing competitive swim & teaching facilities, while balancing emerging leisure needs.

an integrated and connected aquatic, fitness and community complex.

a social hub and community destination.

designed to accommodate future needs.

a highly sustainable development.

linked to the wider transportation network.

light, bright and create comfortable environments.

physically and demographically accessible to all.

multi-generational and flexible for mixed-uses.

located within a park & connected to the wider network of green spaces.



Proposed solution

AQUATICS

LEISURE

- Leisure swimming
- Lessons
- Warm-up / down
- Therapy
- Sauna & steam rooms
- Lazy river
- Hot pools
- Tot zone

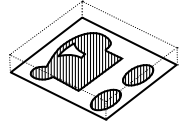

PROGRAM TANK 50M

- Length swimming
- Aquatic group fitness
- Swim lessons
- Leisure diving

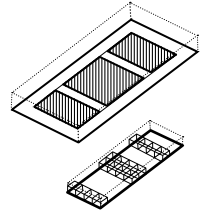

CHANGE ROOMS

- Universal access

FITNESS

- Cardio
- Spin
- Free weights
- Stretching

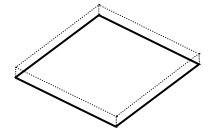

COMMUNITY

WELCOME CENTRE

- Informal social gathering
- Community events
- Cafe

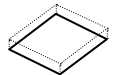

GYMNASIUM

- Basketball
- Volleyball
- Pickleball
- Badminton
- Floor hockey
- Other non-sport activities

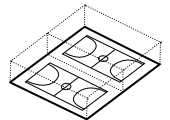

MULTI-PURPOSE

- Arts & crafts
- Childminding
- Group fitness classes
- Meetings
- Bookable spaces

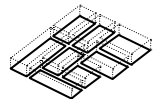

CHILDCARE

- Daycare
- Outdoor play space

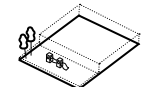

Total Area: 114,295sq ft

The new facility will be 65% larger than the existing 70,000 CGP/CCC.